

ELETTROPOMPE DI SUPERFICIE SURFACE ELECTRIC PUMPS

AJM/AJ

ELETTROPOMPE AUTODESCANTI JET SELF-PRIMING JET PUMPS

APPLICAZIONE

- Possono essere utilizzate per trasferire acqua pulita o liquidi chimicamente non aggressivi, anche in presenza di aria miscelata al liquido aspirato. Sono particolarmente adatte per il sollevamento dell'acqua dal suolo, sistemi di irrigazione per giardino, sistema di pressurizzazione, per irrigazione orti e giardini.

POMPA

- Corpo pompa in ghisa, sottoposto a trattamento in cataforesi
- Girante in acciaio inox
- Albero AISI 304
- Temperatura max del liquido: +40°C
- Altezza di aspirazione manometrica fino a: 9 mt

MOTORE

- Motore con avvolgimento in rame
- Motore monofase con protezione termica inserita nell'avvolgimento
- Classe di isolamento: F
- Protezione: classe IPX4
- Max temperatura ambiente: +40°C

CODICI IDENTIFICATIVI

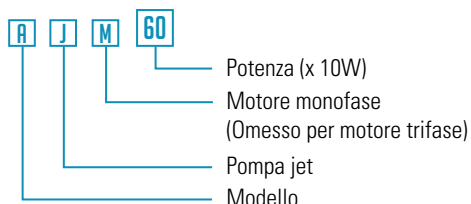

APPLICATION

- It can be used to transfer clean water or other liquids similar to water in physical and chemical properties. It is suitable for lifting water from the well, sprinkling irrigation in garden, pressure boosting of running water and supporting equipment etc.

PUMP

- Cast iron pump body and support under special anti-rust treatment
- Stainless steel impeller
- AISI 304 shaft
- Max. liquid temperature: +40°C
- Max. Suct: +9 m

MOTOR

- Motor with copper winding
- Single phase motor with built-in thermal protective device (auto protection & reset)
- Insulation class: F
- Protection class: IPX4
- Max. ambient temperature: +40°C

IDENTIFICATION CODES

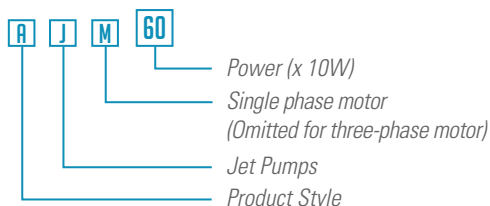

DATI TECNICI | TECHNICAL DATA

Modello Model	Potenza Power		Ampere	Qm ³ /h																Codice Code	€ cad € each
	kW	HP		0	0.3	0.6	0.9	1.2	1.5	1.8	2.1	2.4	2.8	3.0	3.3	3.6	3.9				
Monofase Single Phase				QL/min																	
				0	5	10	15	20	25	30	35	40	47	50	55	60	65				
AJm45	0.45	0.6	3.50	H (mt)	41	36	32	28	25	22	20	18							10AJM45	158,00	
AJm60	0.6	0.8	4.20		45	41	37	33.5	31	28.5	26	24	22.5	21					10AJM60	196,00	
AJm75	0.75	1.0	6.00		40	38	36	34.5	33	31.5	30	29	28	27	26	25	24	23	10AJM75	205,00	
AJm75H	0.75	1.0	6.00		51	47	43	40	37	34.5	32	30	27.5	25					10AJM75H	210,00	
AJm75H con valvola	0.75	1.0	6.00		51	47	43	40	37	34.5	32	30	27.5	25					1030276	230,00	
AJm90	0.9	1.2	6.00		48	46	44	42.5	41	39.5	38	36	35	34	33	32	31	30	10AJM90	224,00	
AJm90H	0.9	1.2	7.00		62	57	53	49	46	43	40	37	35	33					10AJM90H	224,00	
Trifase Three Phase																					
AJ90	0.9	1.2			H (mt)	48	46	44	42.5	41	39.5	38	36	35	34	33	32	31	30	10AJ90	222,00

DIMENSIONI | DIMENSION

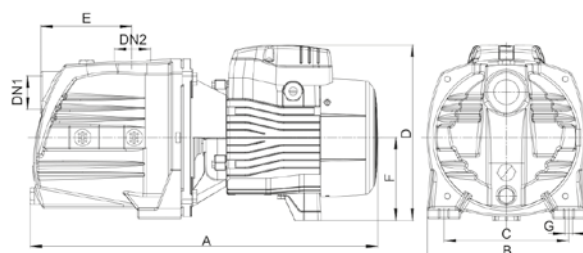

Modello Model	DN1	DN2	A (mm)	B (mm)	C (mm)	D (mm)	E (mm)	F (mm)	G (mm)
AJm45	1"	1"	358	160	105	180	89.5	90	10
AJm60	1"	1"	418	190	150	212	113	100	10
AJm75	1"	1"	418	190	150	212	113	100	10
AJm75H	1"	1"	418	190	150	212	113	100	10
AJm90	1"	1"	418	190	150	212	113	100	10
AJm90	1"	1"	418	190	150	212	113	100	10
AJ90	1"	1"	418	190	150	212	113	100	10

DIAGRAMMA PRESTAZIONI | HYDRAULIC PERFORMANCE CURVE

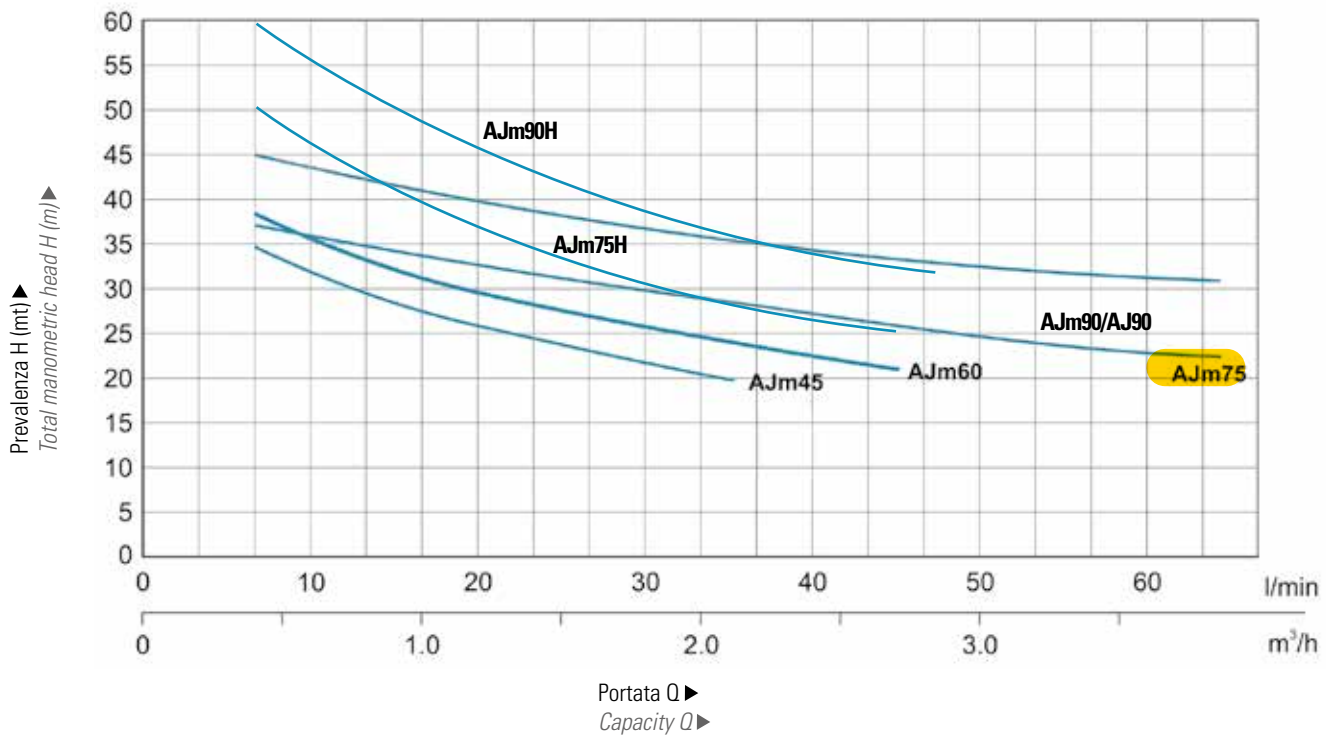

DESCRIZIONE COMPONENTI | MATERIALS TABLE

Pos. Pos.	Part. Part.	Materiale Material
1	Corpo pompa Pump body	Ghisa HT200 Cast iron
2	Tubo di Venturi Venturi tube	PPO
3	Diffusore Diffuser	PPO
4	Girante Impeller	AISI 304
5	Tenuta meccanica Mechanical seal	Grafite/Ceramica Carbon/Ceramic
6	O-ring	NBR
7	Coperchio supporto Support cover	AISI 304
8	Supporto Support	AISI 304
9	Cuscinetto Bearing	
10	Albero motore Rotor	
11	Copri ventola Fan cover	PP
12	Ventola Fan	PP
13	Coperchio Rear cover	Alluminio ZL102 Aluminum
14	Condensatore Capacitor	
15	Copri morsetteria Terminal box	ABS
16	Morsetteria Terminal board	
17	Cassa motore con statore avvolto Stator	

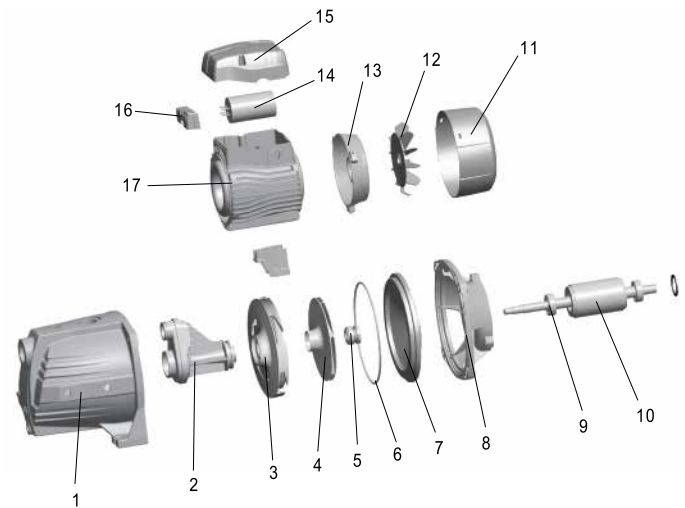

DIMENSIONI IMBALLO | PACKAGE INFORMATION

Modello Model	GW (Kg)	L (mm)	W (mm)	H (mm)
AJm45	10.15	390	185	215
AJm60	14.35	455	215	245
AJm75	15.5	455	215	245
AJm90	16.45	455	215	245
AJm90H	16.45	455	215	245
AJ90	16.45	455	215	245

